

SU 29 - 1.2m RC factory

Kit contents:

- *fuselage
- *canopy
- *cowl
- *stabilizer
- *rudder
- *wings
- *landing gear
- *carbon parts
- *wheel covers
- *building instructions
- *accessory bag

Connection stainless hardware:

- 4x screw M1.6x4 ... ball clevises
- 2x screw M2x5 ... rudder hinges
- 2x screw M2x5 ... pull pull fasteners
- 1x screw M2x8 ... tailwheel axle
- 2x nut M2 ... tailwheel axle
- 2x Allen M3x14 ... landing gear axle
- 4x washer 3 ... landing gear (see Diag.)
- 2x nut M3 ... landing gear (see Diag.)
- 2x tapping screw 2.9x9 ... LG legs lock
- 2x Allen M2.5x6 ... motor attachment
- 2x Allen M3x6 ... alternative dtto
- 2x Z bend ... elevator pushrod
- 1x frame, control arms and horns
- 2x wheel pants holder
- 1x landing gear base mount
- 2x landing gear lock
- 2x firewall holding tab
- 4x ball link clevis
- 2x wheel 50 mm
- 1x wheel 25 mm
- 1x tube 3/2 x 15 mm - elevator pushrod support
- 2x carbon 1x5x150 - elevator reinforcement
- 2x carbon 2x50 - aileron pushrod
- 1x kevlar string 1.5m - rudder pull pull system

CFparts-frame, control arms and horns:

1. rudder hinge, fuselage part (2 pcs)
2. rudder hinge, lower rudder part
3. elevator servo arm extension
4. aileron control horns
5. rudder control horn
6. rudder servo arm extension
7. tailwheel leg
8. elevator control horn

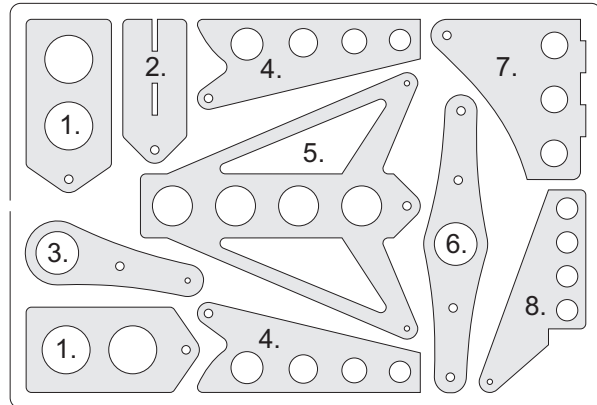

You will also need:

- Allen key No. 2
- Philips screwdriver
- standard screwdriver
- CA glue + activator
- hobby knife
- flat file
- sand paper 100 - 500
- 3 mm drill bit
- a bit of patience for cca 5 hrs

SU 29 – 1.2m aerobatic EPP model
Building instructions

Please follow the Diagram Sheet.

Tip: sand the GF (glass-fibre) parts before gluing

Diag. A, B

Push 2 flat cf strips (1x3x1000 mm) into the slots on the sides of the central fuselage part (the „backbone“). Lay the backbone on its side on your building board and make sure that it is perfectly straight. Apply CA glue over the cf strips and let cure.

Diag. C

Glue the wing halves to the backbone. Note the small tabs that help you align the wing correctly. Slightly push on the thickest part of the wing root to help the wing settle in the correct incidence.

Important: if you glue the wing in normal (not inverted) position – the upper surface facing up – the stabilizer cutout in the backbone should be also facing up. On *Diag. C* the wing and the backbone are depicted in inverted position.

Diag. D

Locate two cf strips, 1x5x850 mm. Cut shallow slits into the wing and backbone, spanwise, both on the upper and lower surface of the wing. Push the cf strips into the slits and make sure that the wing and backbone assembly rests flat and straight on a level building board. Apply thin or medium CA over the strips and let cure. Cut shallow slits according to the mark 2 of the *Diag.* You will later mount the LG (landing gear) locks here.

Diag. E

Likewise cut 2 slits into the stabilizer and push 2 cf strips (1x5x150mm) there. Lay the stabilizer on a flat board and apply CA glue over the carbon strips.

Diag. F

Use medium CA to attach the (black EPP) canopy to the fuselage. Use your hobby blade to separate the upper and lower part of the fuselage.

Diag. G

Rest your (wings and backbone) assembly on your board, inverted (bottom side up). Assemble the LG mount and glue it to the backbone into the slits you made according to *Diag. D* mark 2.

Diag. H

CA glue the lower fuselage part to the (now inverted) backbone. Attach (CA again) the stabilizer to the backbone, first making sure that your alignment is perfect and square.

Diag. I

Drill holes into the LG legs.

Diag. J

Push the LG legs into the LG mount. It may be a very tight fit, in such case use small file to increase the openings. Use 2 tapping screws (2.9x9 mm) to attach the legs to the mount. To release the legs, just loosen the screws a bit. Assemble the landing gear according to the Diag. Gluing the EPP wheel covers to their holding tabs is the last operation.

Diag. K

Now is the right moment to install the aileron servos. Make sure you find the right position (consider cables lengths, or use extension cables). We prefer the location at about 1/3 of the wingspan. Cut out enough material from the wing to make the servo a tight fit. Use hot glue (preferred) or thick (!) CA to glue the servos in place. You may want to cover the servos in masking tape first for protection. Cut and glue the control horns into the ailerons (follow the Diag.). Make sure you have the right geometry in your servo horn – in servo neutral, the horn should be inclined cca 13° - not critical - „backwards“, towards the aileron. Assemble the control links.

Diag. L

Use thin or medium CA to attach the upper fuselage part.

Diag. M

Assemble the tailwheel system and glue it to the lower rudder hinge. Get the other part of the hinge and thread the M2x5 screw through the corresponding holes to make the hinge complete. There is no thread cut in the holes, but using some force you may twist the screws through – they will push their way into the material since the holes are just the right size. Create the upper hinge in the same way, the rudder control horn is part of the upper hinge. Make corresponding cuts into the fuselage and rudder, install the hinges using thin CA. Note – the cut for the lower hinge (and tailwheel mount) in the rudder is T shaped when you look from the front.

Diag. N

CA glue the two plywood tabs into the motor mount.

Diag. O

Install the motor mount assembly into the backbone and fuselage. The motor thrust line is 0° up and 1.3° to the right (the backbone is produced in the correct shape to make this so). Use thin CA.

Diag. P

Elevator control link: the servo is on the side of the backbone. Cut out the material for a tight fit, make sure that the location is within the reach of the servo cable to the receiver. Glue in servo using preferably hot glue, or a thick CA. Again you may cover the servo in masking tape first. Locate carbon tube 2/1 x 500 mm – your elevator pushrod. On the elevator side, glue the stainless Z wire into the tube, leaving cca 10 - 15 mm out of the tube. Put the Z bend through the elevator control horn, cut and CA glue the control horn into the elevator. Test the elevator movement. Thread the orange supporting tube (3/2 x 15 mm) onto the pushrod and glue it to the backbone about half way between the servo and elevator.

Install the Z bend on the servo side, with servo arm in neutral. If the ele. throws are not sufficient, use the included servo extension horn.

Diag Q

Rudder control link: install the servo just like you did the elevator one. Attach the extension servo horn to the original one using kevlar line and CA. Thread the two M2 x 5 screws into the extension horn. The pull – pull system uses the included kevlar line. Glue the line to the M2 screws, you can use them to tighten the line when necessary. On the rudder side, just tie the line into the control horn (and also use a drop of CA to prevent the sharp hole edges from tearing through the line).

Setting up and Trimming

We hope that you know how to connect and set up your RC system. If not, refer to the relevant instruction manual or better ask a more experienced model aviator. For maximum flight envelope, use the biggest mechanically possible control throws. The rudder throws may be slight less, say 50°. The aileron throws should be the same up and down. For first flights, or if you do not feel like an expert 3D flyer, use somewhat lower throws – some 60% of the maximal ones. Use exponentials of 30 to 60% or to your best liking.

For first flights, we recommend centre of gravity (CoG) at some 125 mm from the leading edge (root of the wing). At the beginning, use adhesive velcro tape to attach the battery. This will help you find the right CoG (we like it quite aft, so much that the plane tends to fly „hands off“ both normal and inverted). When happy with the CoG, you may (or may not) cut a slot for the battery in the (upper) fuselage. The vertical CoG may influence rolling tendencies (there should be none) in knife edge (KE) – you may want to put the battery under the backbone if the model rolls to inverted from KE. Some people don't go this far and simply just use mixes to fix KE issues. Our method for getting the right elevator trim is a power off vertical dive – the plane should fall straight down, like a brick J.

Aileron trim should be perfect both normal and inverted – if not, you may have a lateral balance issue. Try putting the battery to the other side of the fuselage, this should do most of the time.

After all these steps, the model should fly straight and also hover without any bad tendencies. Hover can be adjusted by slight thrust line adjustments (insert washers between the motor and the motor mount), but most likely there will be no need for going that far.

Clean rolls (with no „barrel“ tendencies) can be achieved by dialing in the correct aileron differential. If your radio does not allow this, you may just set different up and down aileron throws). Equal up and down throws should work just fine, though.

*Enjoy your new EPP Sukhoi!
Your RC Factory team.*

Specifications:

Wingspan:	1200 mm
Length:	1252 mm
AUW:	600 – 800g
Motor:	200 – 300W outrunner (ca 70 – 120g)
Servos:	12 – 20g good quality servos
Battery:	1600 – 2500 mAh 3s lithium polymer

Diagram sheet 1/2:

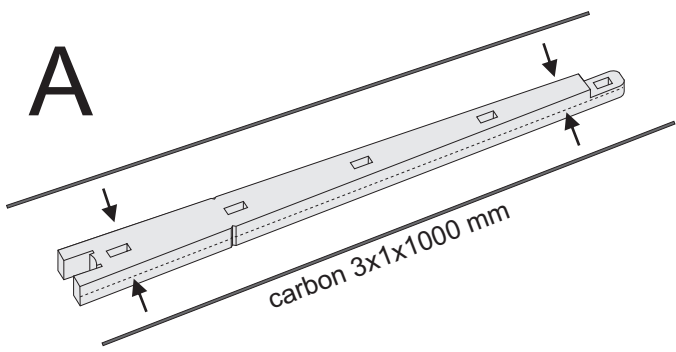

bottom side of wing facing up!
elevator cutout down!

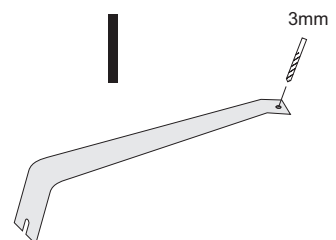
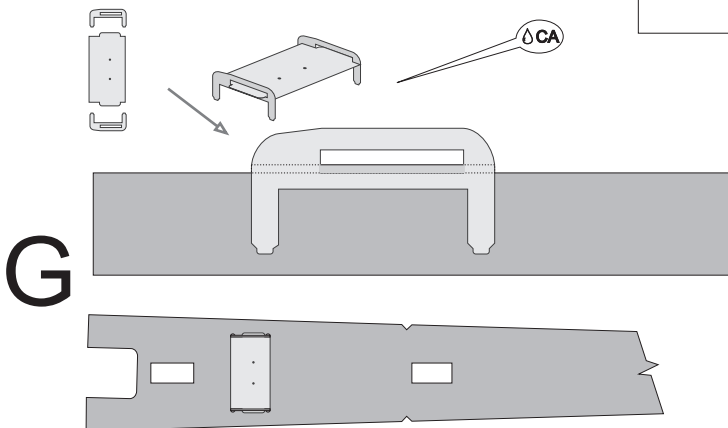
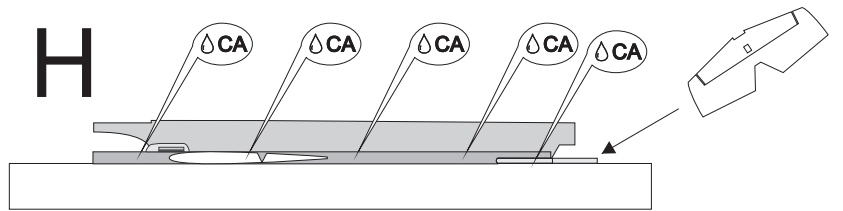
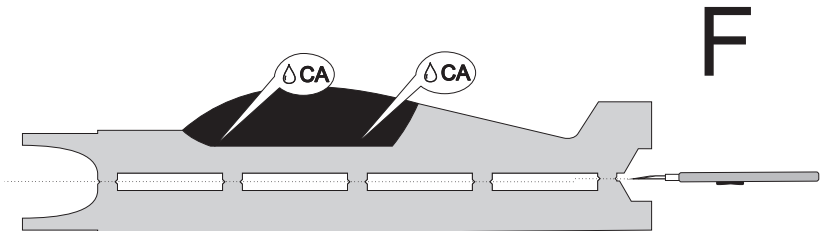
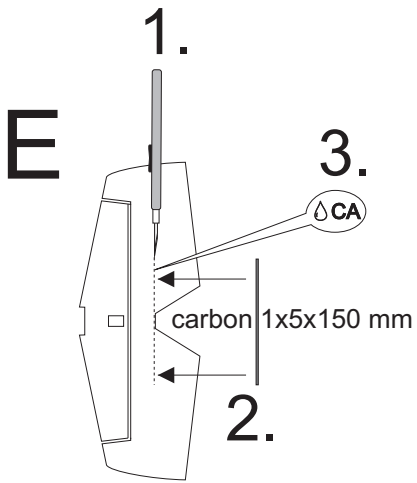
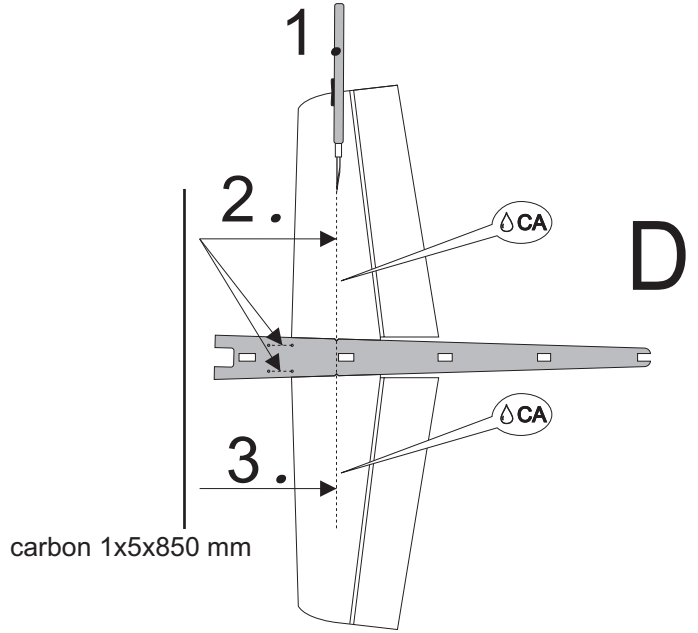
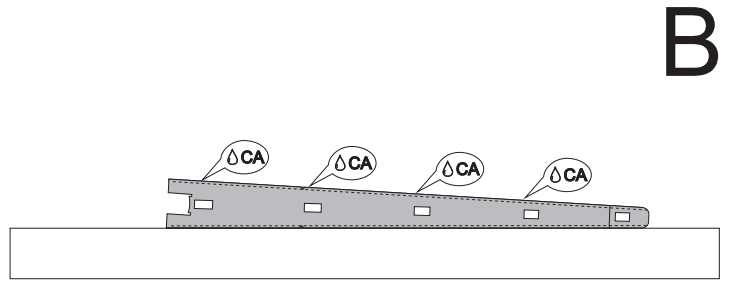
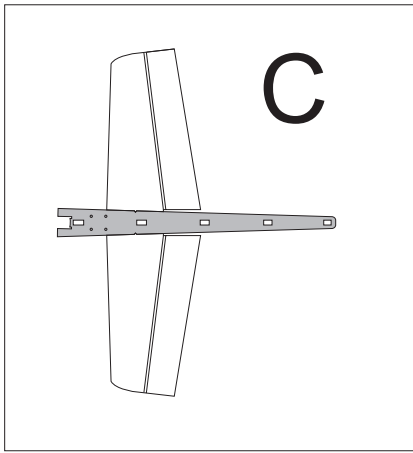
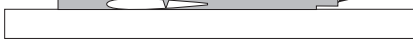

Diagram sheet 2/2:

